

ADAPTERS, IN-SERIES 1.85mm

DC - 65 GHz BULKHEAD MOUNT



MODELS: 5289, 5290

SPECIFICATIONS:

Electrical:

Frequency Range _____ DC – 65 GHz
 VSWR
 DC – 26.5 GHz _____ 1.25:1 Max.
 26.5 – 50 GHz _____ 1.35:1 Max.
 50 – 65 GHz _____ 1.40:1 Max.
 Impedance _____ 50 Ohms
 Operating Temp Range _____ -65°C to +125°C

Mechanical:

Connectors _____ Passivated Stainless Steel
 (Mates with 2.4mm & V* Connectors)
 Conductors _____ Gold Plated Beryllium Copper
 O-Ring _____ 70 Durometer Buna N

*V is a trademark of Anritsu Corp.

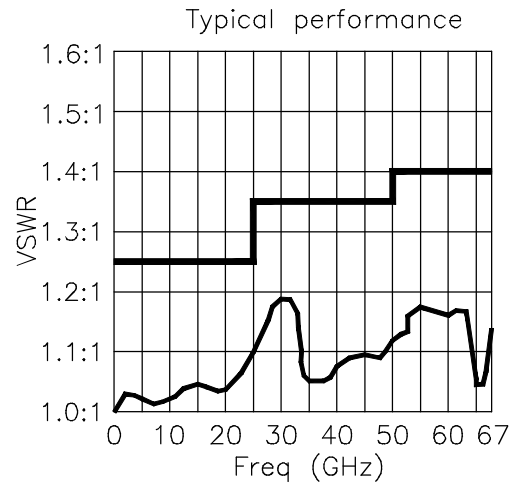

Model Number: **5289**

*Includes O-Ring as Shown

Model Number: **5290**

No O-Ring Included

Recommended
Mounting Hole

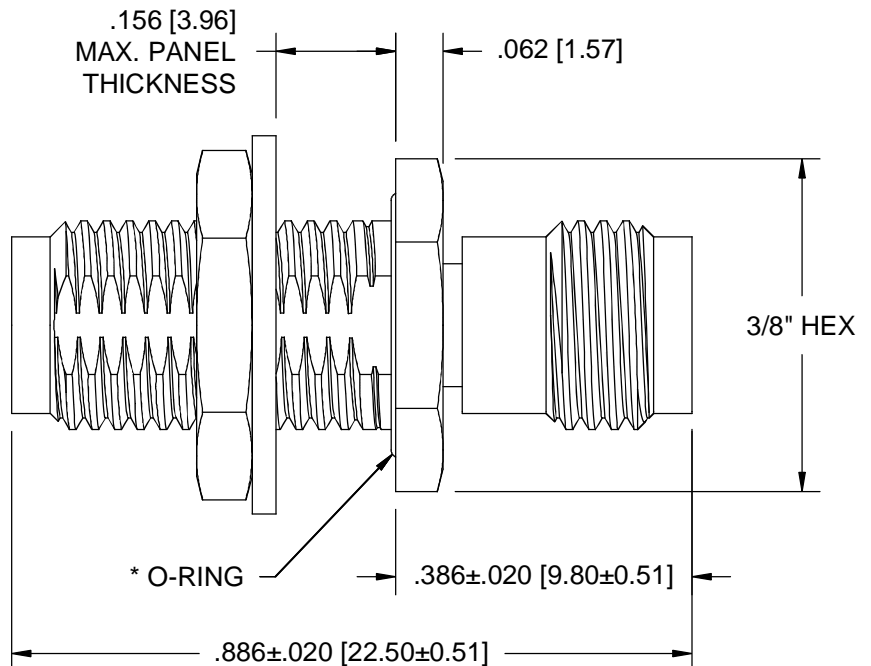
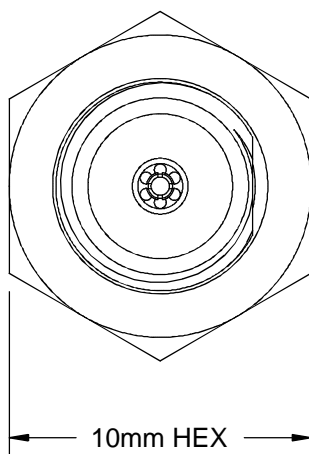
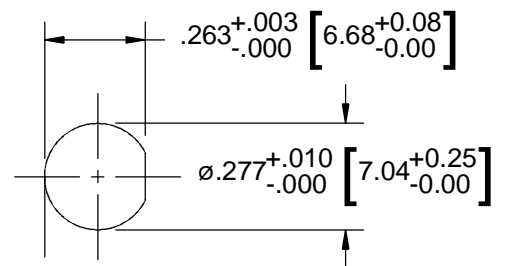

Panel Nut, Lock Washer and O-Ring are Shipped Unassembled.

Note: Dimensions in Brackets are Expressed in Millimeters and are for Reference Only.
 Design specifications are subject to change without notice.
 Contact factory for technical specifications before purchasing or use.

5289; REV B