

# UNDERSTANDING TEMPERATURE & POWER COEFFICIENT IN ATTENUATORS

By Jimmy Dholoo & Rabih Sinno, MCE/Weinschel Corporation

Temperature Coefficient of Resistance, TCR, is a well-known parameter in the Electronics Industry. Power Coefficient of Resistance, PCR, is not such a familiar term. Manufacturers seldom provide PCR specifications for their resistors. TCR and PCR are usually expressed in parts per million per degree (ppm / °C), or parts per million per watt (ppm / W). Applying PCR in an example, a 10-Watt, 100-ohm resistor with a PCR of +/- 200ppm/W could change by +/- 0.2 ohms when subjected to 10 Watts of average power at ambient temperature ( $100\Omega \times 10W \times 200 \times 10^{-6} / W$ ).

Attenuators in their discrete form are usually a combination of chip resistors in a Pi or T network, and the type of resistors selected for such networks depends on the desired frequency, temperature and power handling requirements. The individual chips in such a network might either be thin- or thick-film resistors. For higher frequency applications, attenuators usually take on a distributed form, with a resistive sheet of thick-film or thin-film terminated with suitable metalization, Figure 1. The most common material for thick-film resistors is ruthenium dioxide. Popular thin film materials are nichrome, tantalum nitride and tin oxide.

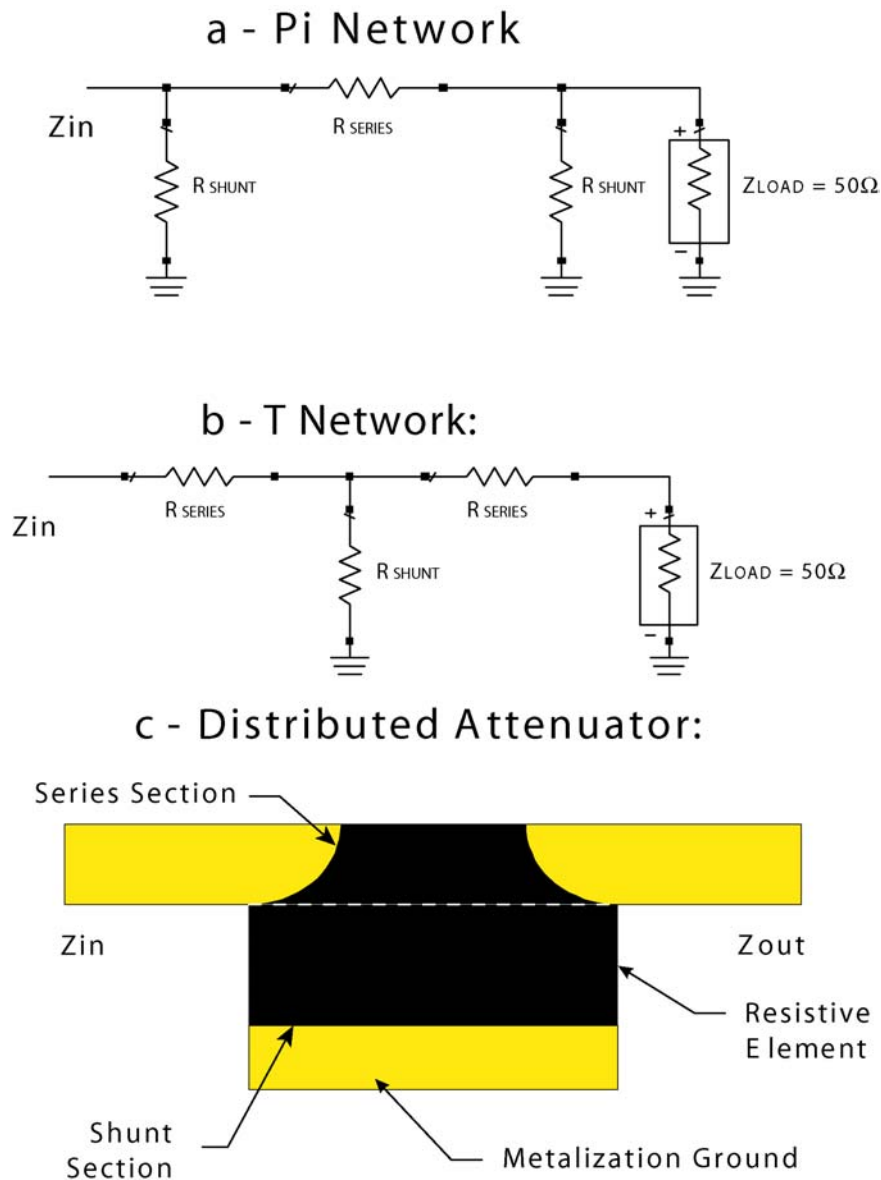

Figure 1. PI and T Network Schematics

Almost all the fixed and programmable attenuators offered by Weinschel specify a Temperature Coefficient of Attenuation (TCA) and a Power Coefficient of Attenuation (PCA) in the product data sheets. Based on the inquiries we receive about the interpretation of these specifications, it seems that some basic explanation is necessary so the end user can correctly forecast the worst case scenario for his system; i.e. what attenuation change might be expected at temperature and power extremes.

## Case 1: TCA of Fixed Attenuators

All of Weinschel’s fixed attenuators are of the distributed type and of a proprietary thin-film Tin Oxide composition. The tin oxide is deposited on a ceramic substrate at 930° C via a chemical vapor deposition process and terminated with gold metalization. Depending on the product type, the substrate could be Alumina, BeO or ALN. The vast fixed attenuator family covers a frequency range of DC to 40 GHz, and the power handling ranges from as low as 2 watts to 1000 watts. The TCA for every fixed product is specified as 0.0004dB/dB/°C because the predominant factor determining the TCA is the TCR of the tin oxide film. The substrate material, the sheet resistivity and the mechanical contacts between the connectors and the substrate and between the substrate and the grounds contribute to the overall TCA, but to a much lesser extent. The TCA is usually measured at a power level low enough so as not to cause any significant warming of the unit. Attenuation is measured at various ambient temperatures over a specified frequency range. The worst-case coefficient arrived at is based on the maximum attenuation change over the frequency band. Military Standard, MIL-A-3933 for fixed attenuators calls for a TCA of 0.0004dB/dB/°C. Over a 100° C ambient temperature change, a 30 dB attenuator would change by a maximum of 1.2 dB ( $30dB \times 100^\circ C \times 0.0004dB/dB/^\circ C$ ) at low signal levels. In reality, the TCA of Weinschel attenuators is 0.0001dB/dB/°C. The maximum change would only be 0.3 dB on a 30 dB attenuator, thus providing a significant guard band to the user.

Figure 2 -- DC Attenuation as a Function of TCR for Two Temperature Extremes, 25 ± 100 °C

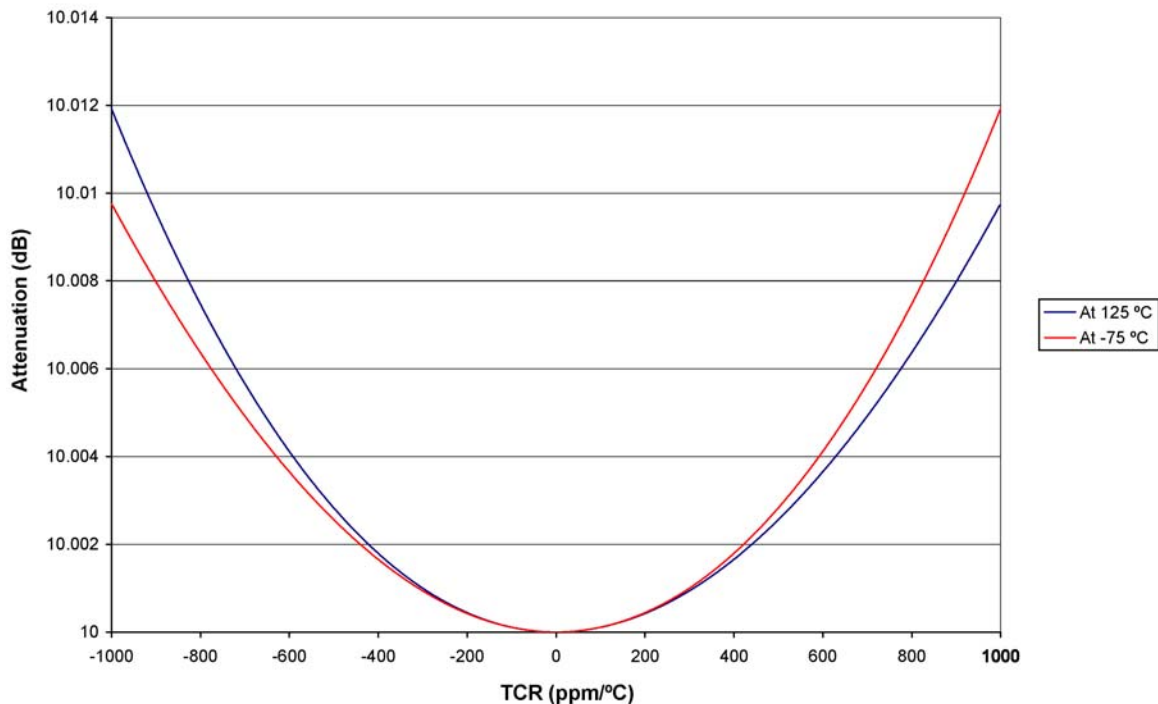
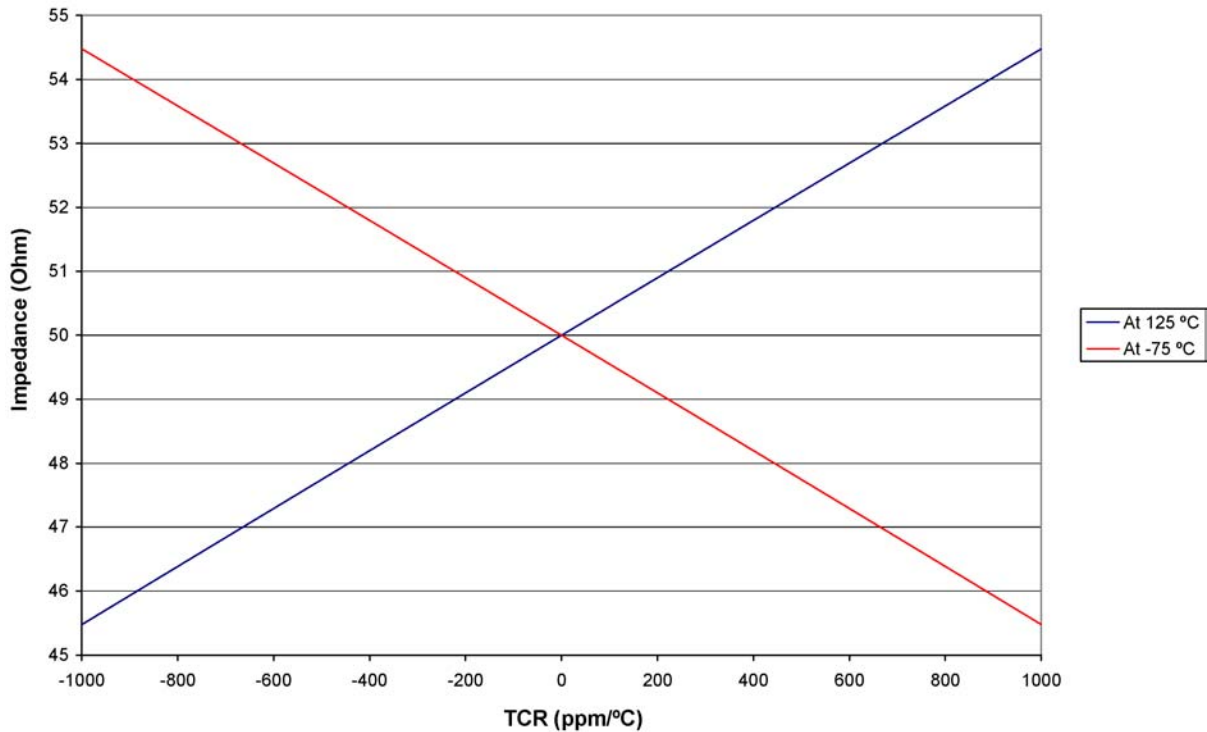

Figure 2 is a theoretical plot showing the attenuation variation on a 10 dB distributed attenuator as a function of the TCR of the resistive thin-film at DC and two temperature extremes, -75°C and +125°C. It is interesting to note that the change in attenuation is rather small over such a wide swing of both temperature and TCR. Figure 3 is a similar plot of the impedance variation of the same attenuator and this shows a significant change from the nominal 50-ohm impedance. Three obvious conclusions can be drawn from these plots:

Figure 3 -- DC Impedance as a Function of TCR for Two Temperature Extremes,  $25 \pm 100 \text{ }^\circ\text{C}$



- As long as the shunt and series resistive elements of an attenuator have the same TCR the attenuation will always increase at DC, independent of the temperature and the magnitude of the TCR. Distributed film attenuators will always behave in this manner because the shunt and series sections are formed from the same resistive film and therefore have the same TCR. Discrete attenuator networks may not behave in this manner because the discrete shunt and series chip resistors may have different TCRs.
- Since an increase in the resistance of the series element increases the attenuation and an increase in the resistance of the shunt element decreases the attenuation the overall change in the attenuation is very small and far less than the change in the individual resistors. Similar reasoning holds true when there is a decrease in the resistance of the series and shunt elements.
- Materials with poor TCR Figureures will seriously impact the impedance of distributed attenuators and significantly degrade the SWR, with little effect on the DC attenuation.

## Case 2: PCA of Fixed Attenuators

Though the specified TCA of all attenuators is the same, the PCA varies across the product line since it is no longer just a function of the tin oxide resistive film. It also depends on the substrate material, metalization, packaging, heat sinking and forced cooling, if any. The effect of high power/high voltage on this resistive film is quite different from that of a temperature increase at low voltages/low power. A detailed discussion of this is beyond the scope of this article but it is important to note that this effect is a function of the electrical stress in the film and will depend on the dimensions of the resistive film, and so is a function of the size and shape of the resistor. Also, it is worth clarifying that referring to this high voltage effect as a “Power Coefficient” is misleading since the rate of change of resistance with applied voltage is not constant and the film exhibits some degree, albeit small, of non-linearity.

From the Weinschel fixed attenuator product line, a typical 2 W attenuator has a PCA of  $< 0.005 \text{ dB/dB/W}$ , so a 30 dB unit would change by less than 0.3 dB ( $30\text{dB} \times 2\text{W} \times 0.005\text{dB/dB/W}$ ) across the full frequency band, when the incident power increases from, say, 10mW to 2 Watts. Similarly, a 500W unit with a PCA of  $0.0001\text{dB/dB/W}$  would change by less than 1.5dB ( $30\text{dB} \times 500\text{W} \times 0.0001\text{dB/dB/W}$ ) over its operating frequency band when the incident power increases from a low level signal to the full 500 watts.

PCA measurements are not easily made. Just as the TCA is measured at a constant low power level with varying ambient temperatures, the PCA must be measured at a constant ambient temperature of 25°C with varying power and over the entire operating frequency range. To carry out such measurements with good accuracy requires a set of high-power, broadband bias tees and good matching techniques. The test set-up is shown in the MIL- A-3933 document.

### Case 3: TCA of Switched Programmable Attenuators

Switched Programmable attenuators typically comprise several attenuator “cells”, usually in a binary sequence: 1 dB, 2 dB, 4 dB, 8 dB, 16 dB, 32 dB etc, Figure 4. These cells are selectively switched ON from their ‘zero’ state, using DPDT relays for electromechanical models and PIN diodes, for solid state versions. Programmable attenuators basically have two states, a zero state when the unit is sitting in its minimum insertion loss position and an attenuate state when the unit is sitting in any of the selected attenuation positions. The interpretation of TCA for these products has at times raised questions because there are two TCA Figures associated with them. The first is the **Absolute TCA**, which is derived from the total change in any selected attenuation, between two temperatures at low signal levels. The second is the relative or **Incremental TCA**. Programmable attenuators are frequently installed in systems and instruments to accurately control RF signal levels. Their insertion loss in the ZERO attenuation position usually becomes part of the overall system loss and is zeroed out in the normalization process. What is important in such cases is the accuracy of the incremental attenuation with reference to the normalized state and, therefore, it is the Incremental TCA that is more relevant to the designer/user. Incremental TCA is derived from the change in the incremental attenuation state at two temperatures; i.e., the normalization of the zero is carried out at both temperatures.

The blue plot in Figure 4 shows the change in the zero state attenuation of an 8 cell electromechanical unit. It was generated by first normalizing its zero state loss at room temperature and then raising the ambient to 100°C. The major attenuation change over temperature comes from the 8 relays. Typically a 75-degree change causes a 0.5 dB change in the Zero insertion loss (0.063dB per relay). For this unit, if normalization were carried out at 25°C, the 1 dB cell switched ON and the ambient raised to 100°C, the 1 dB cell would read 1.5 dB at around 1.5 GHz. This would yield the worst-case **Absolute TCA of 0.0066 dB/dB/°C** (0.5dB /1dB/75°C). As a comparison, the red plot in Figure 4 shows that the Incremental attenuation change of the 32 dB is only 0.05 dB at about 2 GHz because we measure it at 25°C with one normalization and again at 100° C with another normalization. So all changes due to the relays are masked and the worst-case **Incremental TCA** works out to be **0.000021 dB/dB/°C** (0.05dB/32dB/75°C). This shows that the ruthenium based thick-film attenuators screened on a ceramic substrate hardly change over this temperature range. Almost all the temperature variance is therefore attributable to the relay contacts.

### Case 4: PCA of Programmable Attenuators

The PCA for the relay based programmable attenuators is specified at 0.005 dB/dB/W. This PCA, unlike the TCA, is almost fully attributable to the thick-film attenuators since the insertion loss of the 8 relays is almost the same at 10 mW and at 1 Watt (the max power rating of this unit). Incremental PCA therefore has no meaning and is not specified for this unit.

### Conclusion:

An attempt has been made to provide some basic insights into TCA and PCA. Although the focus has been on Tin Oxide and distributed film attenuators, the reasoning is valid for other film compositions and discrete attenuator networks.

**Figure 4 -- 8 Cell Relay-Based Programmable Attenuator**  
 Change in the Absolute and Incremental Attenuation from 25 °C to 100 °C

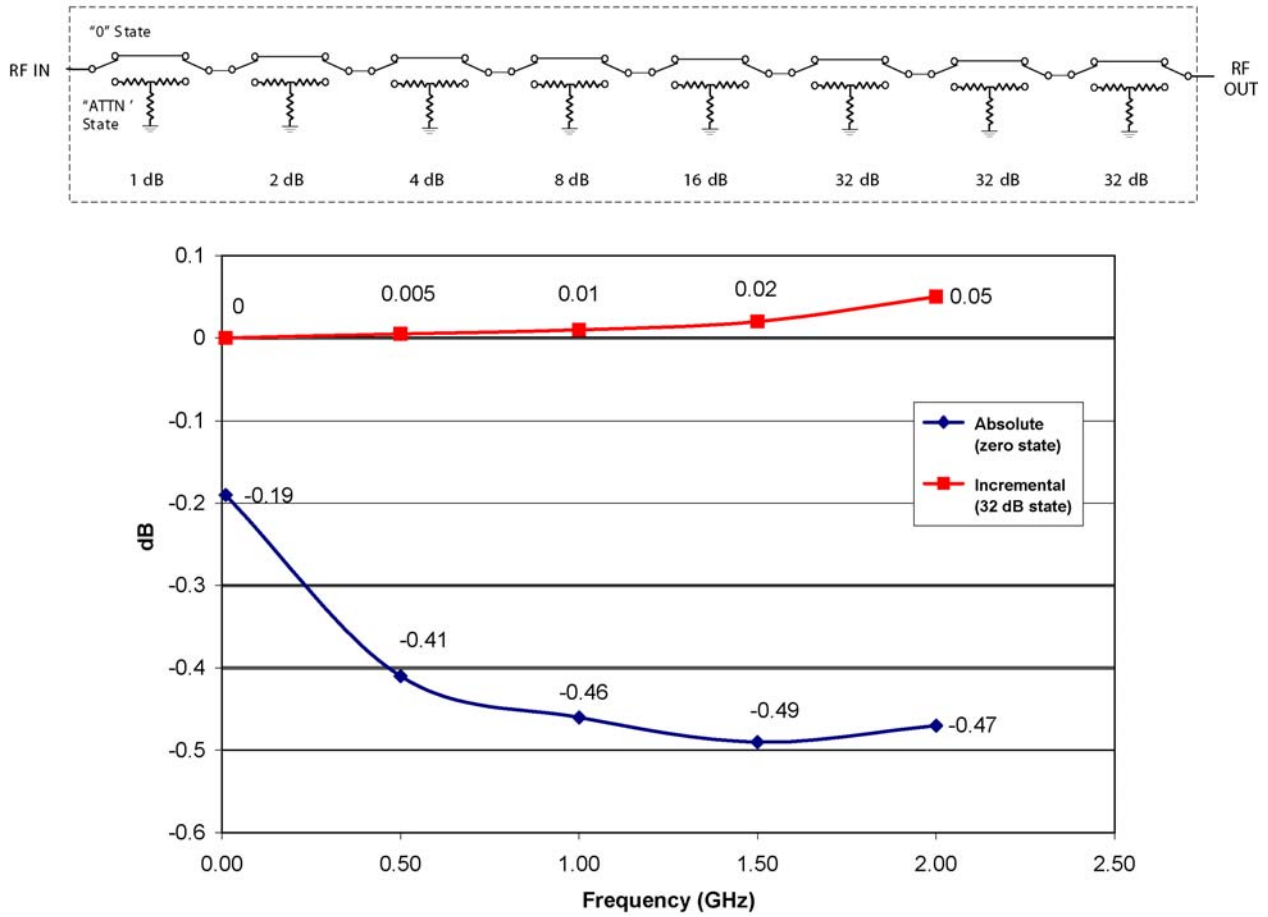

Jimmy Dholoo, VP Engineering and Rabih Sinno, Design Engineer are part of the Components Engineering Staff at MCE/Weinschel Corporation, located in Frederick, MD. Mr. Dholoo and Mr. Sinno can be reached at (301) 846-9222 or [jdholoo@weinschel.com](mailto:jdholoo@weinschel.com).

*Reference: Tin Oxide Resistors By R.H.W. BURKETT, J. Brit. I.R.E. Vol 21, No.4, April 1961*