

# Filtered Low Noise GPS Amplifier

## Summary

A new GPS low noise amplifier has been developed which offers the user performance flexibility in amplifying either L1 (1575 MHz) or L1 and L2 (1227 MHz) GPS signals. Through the use of modular assembly and model-specific configurations, this amplifier can be set up to meet a user's specific requirements with regard to gain, operating voltage, and bias configuration while still maintaining a low 1.6 dB (typical) noise figure.

The bias voltage can be applied through the external RF output or through an external connector. As an alternative method, a power supply OR'ing circuit allows the user to purchase one component that can be powered via either means. The article discusses the importance of placing a high-quality, low-loss filter ahead of the amplifier to prevent intermodulation distortions even though this placement raises the system noise figure. The article also addresses the option of using a limiter diode and the placement of this component in the system lineup.

## Background

GPS navigation and timing systems have become ubiquitous throughout the commercial, consumer, and military marketplace. APITech has manufactured GPS LNA's for both commercial and military customers. These designs have evolved into a product that is flexible enough to satisfy most applications and exhibits leading performance at a marketable cost.

The stability of the design and the quicker turn around time (stock to 4 weeks) make it a ready offering for navigation, timing, and other microwave customers. As will be demonstrated in this paper, the design also lends itself to future developments in GPS navigation, specifically the L1/L2A and L1/L5 signals soon to be implemented. Since the initial deployment of the GPS system, numerous manufacturers have developed filter and amplifier circuits to address the needs of the various users. The resulting low-noise amplifiers each fill a

different niche in the GPS-based navigation and timing marketplace. APITech's filtered LNA's address the market for moderate volume, high-reliability, and high-performance requirements. These designs exhibit excellent anti-jam performance by delivering excellent filtering of interferers while delivering the best dynamic range possible. The product offered is not the lowest cost because packaging and RF performance contribute to a higher manufacturing cost.

The legacy product has been configured with many options over the years, but continues to use the same proven circuits. Options included different RF connectors (SMA, N, TNC, and SMP) to support customer requirements. The power supply could operate as low as 4V and as high as 40V with the proper input bias networks.

As the various customer demands were met, the design continued to evolve in response to requests and complaints. The RF lineup remained the same and statistical data regarding the noise figure performance was collected on hundreds of parts. The main improvements were in packaging and DC bias protection. The packaging changed internally to include a conductive thermo-compression mount for the ceramic filter elements. This improvement reduced the assembly and rework time while providing a greater thermal operating range.

The DC bias improvements included adding high-power dropping resistors to allow a larger operating voltage range. Transient Voltage Suppression (TVS) diodes provided enhanced immunity to power supply voltage spikes. A zener diode voltage clamp improved the LNA's immunity to excessive input voltages.

All of these improvements over the past ten years of product development have combined to produce a unit that is robust enough for a military and missile environment while being economical to offer as a high-end commercial product.

# Filtered Low Noise GPS Amplifier

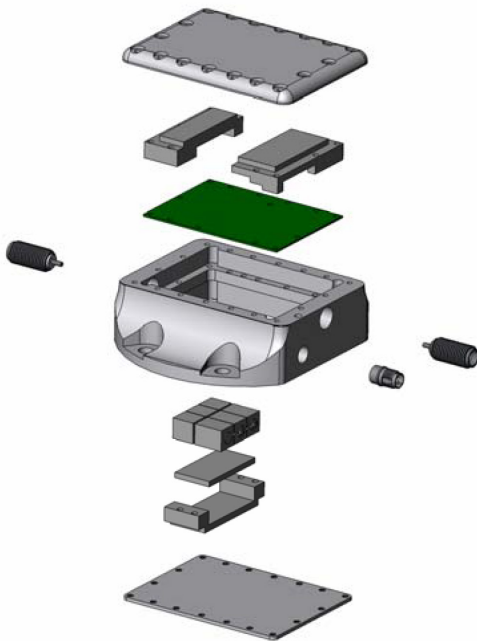
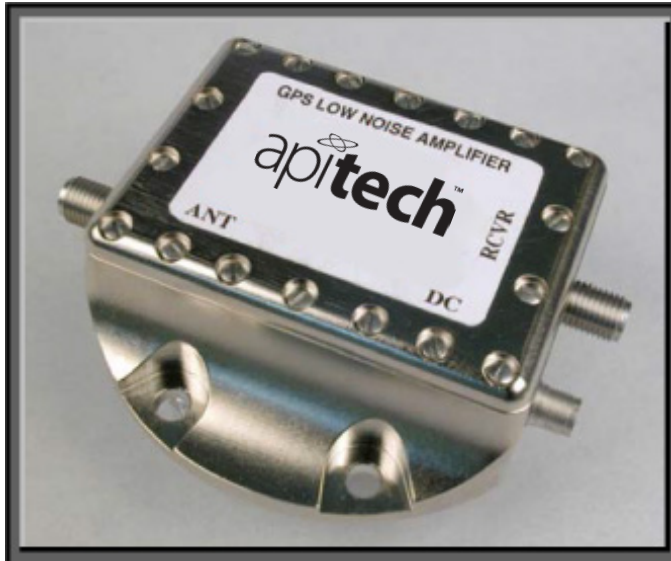

*This exploded view depicts the major components of the new design.*

The housing structure retains the legacy footprint for tapped mounting holes while adding a new four-hole flange pattern. The external power connector (MR01) is compatible with that of the legacy design.

Note conductive compression pad for single or double-diplexed filter elements. Shield covers over the high-gain RF circuitry reduce the chances of package-induced oscillations.

A GPS system's accuracy is depends primarily upon satellite geometry and the number of received signals. Accuracy is improved when the system receives as many satellites that are in view as possible.

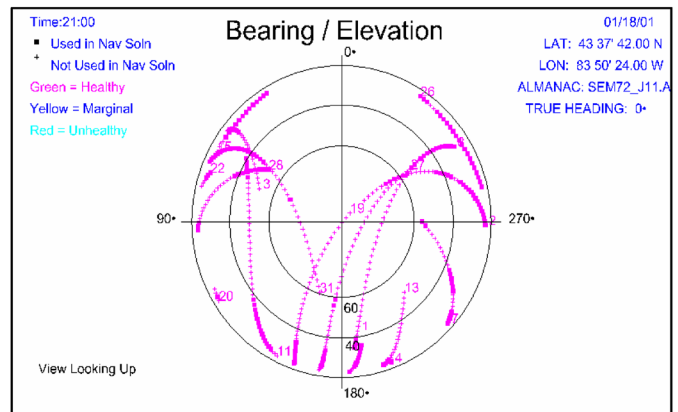

Three factors contribute to reception: antenna design, preamplifier noise figure, and interference immunity. Not much we can do about physical obstructions in the receive path.

### Methods to reduce DOP:

- Use DGPS to reduce the errors in the inputs
- Improve DOP by using more satellites
- Take your measurements when the satellites are spread out over the sky (better geometry)
- Average the GPS position readings over time

Antennas are designed to operate into a 50 ohm resistive load. APITech's LNA employs a balanced transistor amplification stage. Most competitors with product offerings in the L1 frequency use a single transistor in order to reduce cost. The balanced amplifier approach provides a broadband match thereby preserving the stopband attenuation performance of the ceramic filters while allowing the

## Filtered Low Noise GPS Amplifier

transistors to be matched at their optimal reflection coefficient for noise figure performance ( $\gamma_{opt}$ ). Without a balanced stage, matching the transistor at  $\gamma_{opt}$  results in a non-ideal return loss and such an approach degrades the stopband performance of any filter preceding the amplifier.

Finally, using a balanced stage provides better dynamic range as the input signal is split between the two transistors allowing larger in-band interfering signals to be processed without distorting the lower level GPS signals. The balanced input establishes a predictable impedance for the antenna and any interconnecting cable. Perturbations of the input match usually results in distortion of the antenna pattern and a reduction in system performance. Naturally, any reflections contribute to additional losses and therefore higher noise figure.

Most commercial grade GPS LNA's offer close to 1 dB NF, but they do not include the losses of a filter or pair of filters before the amplifier. This line of LNA's exhibits 1.6 dB noise figure performance for both L1 and L2 bands while maintaining excellent VSWR (return loss) performance. While low NF is an important performance parameter, it is not the sole indicator of the amplifier's performance in the real world.

The input 1dB compression is established by the output amplifier stage. Gain is trimmed through the use of an output resistive attenuator. Specifying more gain than required results in a lower input 1dB compression value. The best results are obtained when the 14 dB LNA is employed.

Although the LNAs are available with wide standard operating power supply ranges, the best operational results are achieved when the supply voltage is properly selected. Lowest operating voltage is determined by adding dropout voltage to DC voltage drop through coaxial center conductor or supply lines, if externally biased. Maximum operating voltage is driven by the maximum voltage available from the driving receiver.

Most receivers equipped with integral LNA supplies power the amplifier by applying the DC bias on the coaxial line. The receiver uses a window comparator to determine when the LNA is malfunctioning by either drawing too much or too little current. If the LNA is not selected with appropriate care, the user may be given a false alarm.

A commercial ATC transponder generates at least 500 watts peak power, so we will likely need some input power protection in the LNA to prevent damage from the high power. In the older systems (L1/L2 or L1 only), the bandpass filters provided significant attenuation to this band of frequencies. Since the L5 frequency falls so close to the ATC radar band, the GPS LNA must incorporate some sort of limiting action to prevent damage to the low noise PHEMT transistors.

**This example plot shows a potential solution to a single frequency L5 design requirement.**

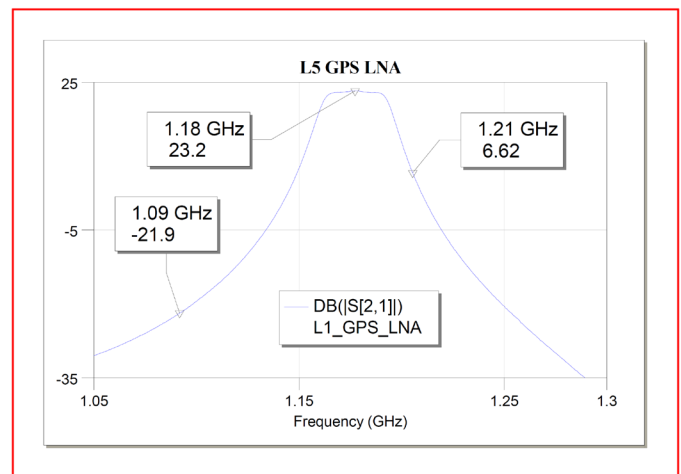

A 3-pole ceramic filter attenuates the transmitted RF pulse by 44 dB, reducing it to a level that is tolerable to a companion GPS receiver.

These critical parameters were identified by Yunchun and Tou (see reference at end of presentation) for interference protection in spread spectrum systems. The authors also called for a tunable bandpass filter when frequency hopping was included in the system architecture.

# Filtered Low Noise GPS Amplifier

As can be observed, the use of dual diplexed filters (either L1/L2 or L1/L5) results in symmetrical passband characteristics.

In order to prevent damage to the amplifier or the receiver due to radiation from co-located emitters, a limiter is normally installed somewhere in the circuit.

Even without adding an additional component, one of the amplifier stages will saturate and provide protection of the receiver. Placing the limiter in front of the filters is not usually recommended.

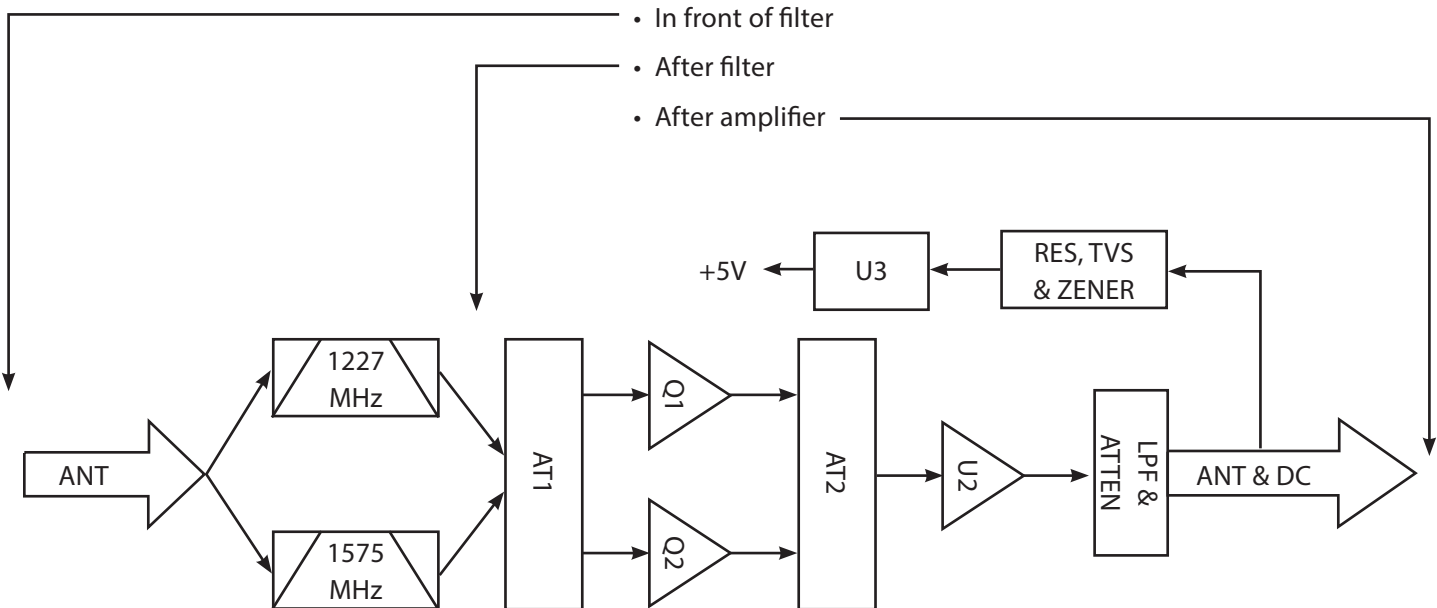
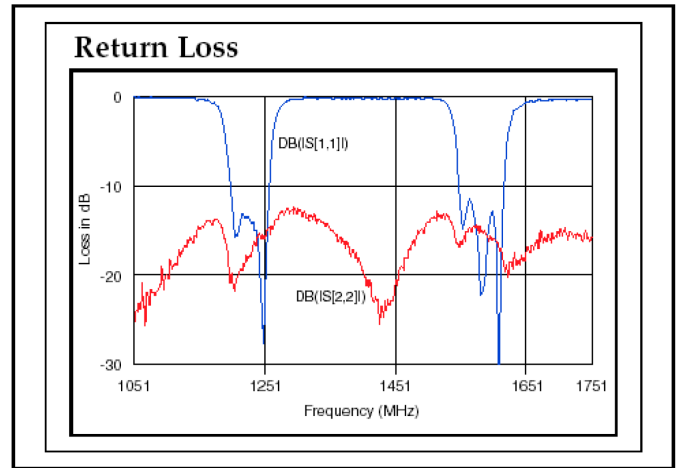

# Filtered Low Noise GPS Amplifier

The limiter diode acts as a non-linear circuit element when pulsed resulting in the generation of numerous spurious products. This position provides the most front-end protection, but at the expense of reduced anti-jam operation. Another disadvantage to this placement choice is that the limiter acts upon all signals, even those outside of the filters' passbands.

A better alternative is to place the limiter after the diplexed filter assembly. This placement option reduces the thermal load on the limiter diode as well as serves to reduce frequency response to only in-band and adjacent-channel interferers. This position is the preferred choice.

Placing the limiter after the amplifier is best if overall integrated energy into the receiver is an important consideration. Some user receiver front ends are very sensitive to overdrive. In these instances, it may be necessary to specify a diode both after the filter and after the final amplifier.

## References:

Yunchun, Shen and Tou, C.P. "A Scheme for Further Strengthening Interference

Protections of Spread Spectrum Communication Systems" 1990, IEEE CH2903-3/90/0000-0532